

-P Probe Installation (Insertion Mounting - Oval Ducts - Type B)

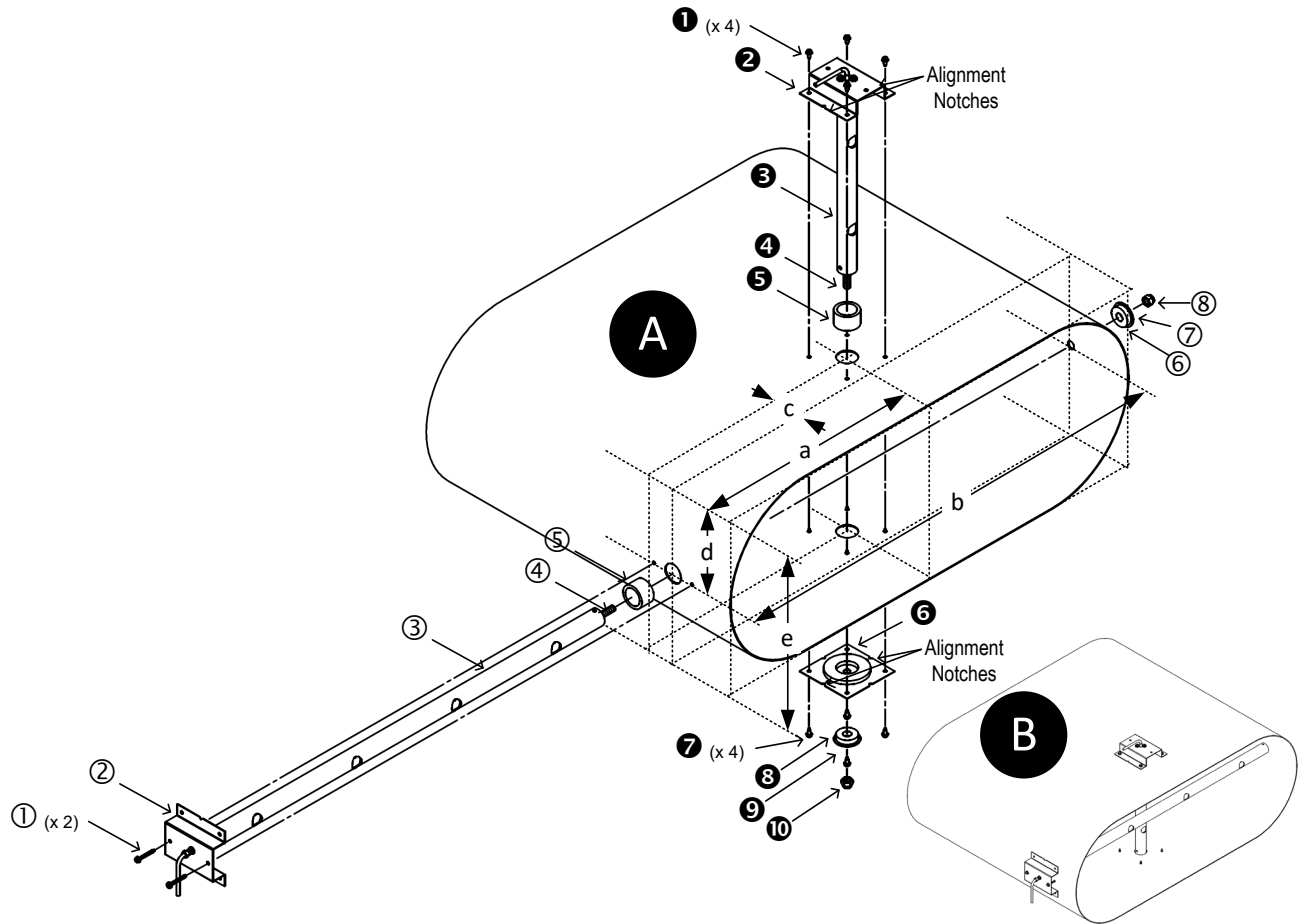

Step 1. Select a location in the duct or plenum opening that meets or exceeds EBTRON's recommended placement guidelines.



If the location does not meet or exceed placement guidelines the installed accuracy may be compromised and field adjustment may be necessary.

Step 2. Probes are ordered and labeled *Probe Length x Adjacent Side Length*. One probe is installed in the major axis (longer dimension) and a second probe is installed in the minor axis (shorter dimension) on Type B installations. Verify that the duct size matches the size ordered.



If the probe length ordered is incorrect, the sensors will not be located in the proper location, thus affecting the installed accuracy. Contact EBTRON customer service for more information.



If the actual size of the duct is not equal to the size ordered, the AREA parameter must be changed in the transmitter to display the proper airflow rate in CFM [l/s].



Do not cut the probe! Cutting the probe will void warranty.

REFER TO FIGURE "A" WHEN COMPLETING STEPS 3 TO 22.

Step 3. Vertically mounted probes subject to water condensation or accumulation (typically supply air and outdoor air intakes) should be mounted so that the cable side of the probe is at the top of the duct.

Step 4. Draw a line on the outside of the duct side chosen as the insertion side that is perpendicular to the edge of the duct and the direction of airflow.



Use a carpenter's square or similar tool to ensure the probes are in the same plane and perpendicular to airflow and to locate the edge of the minor axis (shorter dimension) radius that represents the edge of the duct.

Step 5. Mark a center-point where the shorter probe will be located in the middle of the flat side of the flat oval, dimension 'a' = 'b'/2, where 'b' is the major axis (longer) dimension of the flat oval including any internal insulation.

Step 6. Use the terminal mounting plate [6] as a template to locate the position for the four insertion mounting bracket screws [1]. Position the terminal mounting plate [6] on the duct with the foam gasket pointing away from the duct so that the center-point marked in Step 5 is in the center of the center-hole of the terminal mounting plate [6]. Position the terminal mounting plate [6] so that the center-line notches of the plate are aligned with the line drawn in Step 4. Mark the location of the four insertion mounting bracket screws [1] that secure each insertion mounting bracket [2].



Probes less than 18 inches do not have a terminal mounting plate [6]. Remove the large foam gasket [5] from the probe tube [3] and insert a probe into the duct after completing step 7. Use the probe mounting bracket [2] as a template to mark the location for the four mounting screws [1]. Use the alignment notches on the probe mounting bracket [2] to ensure proper alignment in the duct.

Step 7. Drill a 1-1/8 inch hole at the probe center-point marked in Step 5.

Step 8. Drill appropriately sized pilot holes for each insertion mounting bracket screw [1] location (screws not provided) marked in Step 6.

Step 9. If the probe is provided with the terminal mounting plate [6], follow Steps 10 to 14, otherwise skip to Step 15.

Step 10. On the opposite side of the duct, mark a line perpendicular to the edge of the duct and the direction of airflow directly across from the line marked in Step 4.

Step 11. Mark a center-point on the line drawn in Step 10 directly across from each center-point marked in Step 5.

Step 12. Use the terminal mounting plate [6] as a template to locate the position for the four terminal mounting plate screws [7]. Position the terminal mounting plate [6] on the duct with the foam gasket pointing away from the duct so that the first center-point marked in Step 11 is in the center of the center-hole of the terminal mounting plate [6]. Rotate the terminal mounting plate [6] so that the center-line notches of the plate are aligned with the line drawn in Step 10. Mark the location of the four terminal mounting plate screws [7] that secure the terminal mounting plate [6].

Step 13. Drill a 1-1/8 inch hole at each probe center-point marked in Step 11.



Drilling the larger mounting hole, in lieu of a hole the size of the terminal mounting bolt, facilitates installation of longer probes.

Step 14. Drill appropriately sized pilot holes for each terminal mounting plate screw location (screws not provided) marked in Step 12.

Step 15. Make sure the large foam gasket [5] is installed on each probe tube [3] against the insertion mounting bracket [2].

Step 16. Insert the probe tube [3] in the duct with the airflow directional arrow pointing in the direction of airflow (it is ok if the arrow is upside down).

Step 17. Secure the insertion mounting bracket [2] to the duct with the four mounting screws [1] selected.

Step 18. If the probe is provided with the terminal mounting bracket [6], follow Steps 19 to 21, otherwise skip to Step 22.

- Step 19. Place the terminal mounting plate [6] over the terminal mounting bolt [4] of the probe and secure the terminal mounting plate [6] to the duct with the four mounting screws [7] selected. The foam gasket on the plate should be facing the duct.
- Step 20. Place the small foam gasket [8], large fender washer [9] and lock nut [10] on the terminal mounting bolt [4].
- Step 21. Tighten the lock nut [10] until the small foam gasket [8] is compressed to approximately 50% of its original thickness.
- Step 22. Mark a center-point where the longer probe will be located, offset by dimension 'c' (2 in. [50mm]) from the shorter probe, in the middle of the radiused side of the flat oval, dimension 'd' = 'e'/2, where 'e' is the minor axis (shorter) dimension of the flat oval including any internal insulation.



Use a carpenter's square or similar tool across the flat edge of the oval to locate the center-point on the of the radiused side.

- Step 23. If the probes are provided with the terminal mounting bolt [4], follow Steps 24 to 25, otherwise skip to Step 26.
- Step 24. Mark a center-point directly across the duct from the points marked in Step 22.
- Step 25. Drill a 1/2 inch hole at the probe center-point marked in Step 24.
- Step 26. Drill a 1-1/8 inch hole at the probe center-point marked in Step 22.
- Step 27. Remove the large foam gasket [5] from the probe tube [3] and insert the probe into the duct. Use the probe mounting bracket [2] as a template to mark the location for the two center-line mounting screws [1]. The mounting bracket will self-align on the round portion of the oval to the direction of airflow. Remove the probe from the duct.



Removal of the foam gasket ensures that the insertion mounting plate [2] lays flat on the duct and properly aligns in the direction of airflow.

- Step 28. Drill appropriately sized pilot holes for each insertion mounting bracket screw [1] location (screws not provided) marked in Step 27.
- Step 29. Make sure the large foam gasket [5] is installed on each probe tube [3] against the insertion mounting bracket [2].
- Step 30. Insert the probe tube [3] in the duct with the airflow directional arrow pointing in the direction of airflow (it is ok if the arrow is upside down).
- Step 31. Secure the insertion mounting bracket [2] to the duct with the two mounting screws [1] selected.
- Step 32. If the probe is provided with the terminal bolt [4], follow Steps 33 to 34, otherwise skip to Step 35.
- Step 33. Place the small foam gasket [6], large fender washer [7] and lock nut [8] on the terminal mounting bolt [4].
- Step 34. Tighten the lock nut [8] until the small foam gasket [6] is compressed to approximately 50% of its original thickness.
- Step 35. Probe installation is complete! Figure "B" shows the completed two probe installation.